

# GROUND FLOOR PLAN

## DEVELOPMENT SUMMARY

**SITE ANALYSIS:**

SITE AREA:	1399M <sup>2</sup>
PROPOSED UNIT 1 AREA ANALYSIS: PROPOSED DWELLING AREA (INCLUDING GARAGE):	152.2M <sup>2</sup> (14.3 SQ)
PROPOSED UNIT 2 AREA ANALYSIS: PROPOSED DWELLING AREA (INCLUDING GARAGE):	104.7M <sup>2</sup> (11.2 SQ)
PROPOSED UNIT 3 AREA ANALYSIS: PROPOSED DWELLING AREA (INCLUDING GARAGE):	143.9M <sup>2</sup> (15.4 SQ)
PROPOSED UNIT 4 AREA ANALYSIS: PROPOSED DWELLING AREA (INCLUDING GARAGE):	142.7M <sup>2</sup> (15.3 SQ)
PROPOSED UNIT 5 AREA ANALYSIS: PROPOSED DWELLING AREA (INCLUDING GARAGE):	106.8M <sup>2</sup> (11.4 SQ)
PROPOSED UNIT 6 AREA ANALYSIS: PROPOSED DWELLING AREA (INCLUDING GARAGE):	152.2M <sup>2</sup> (16.3 SQ)

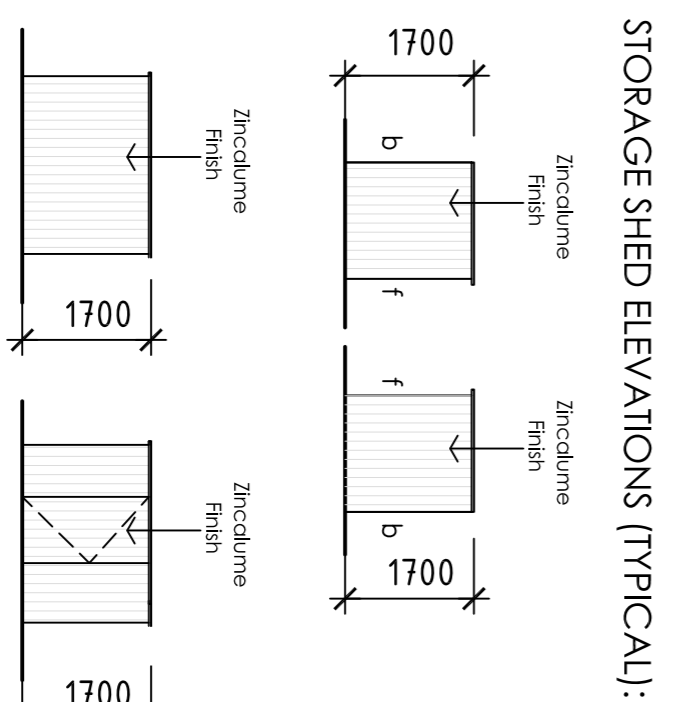
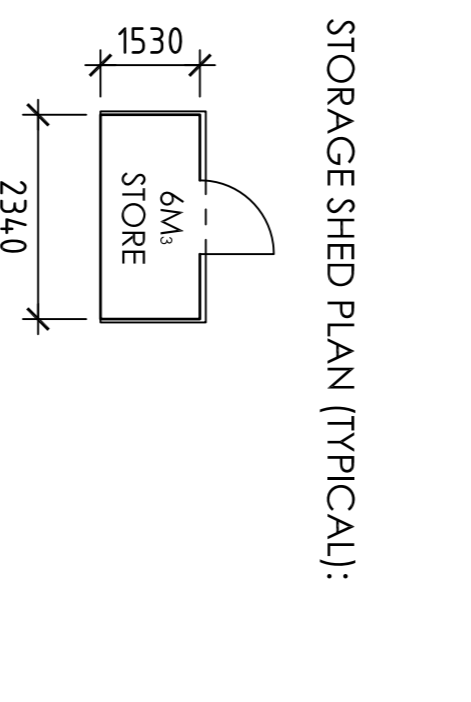
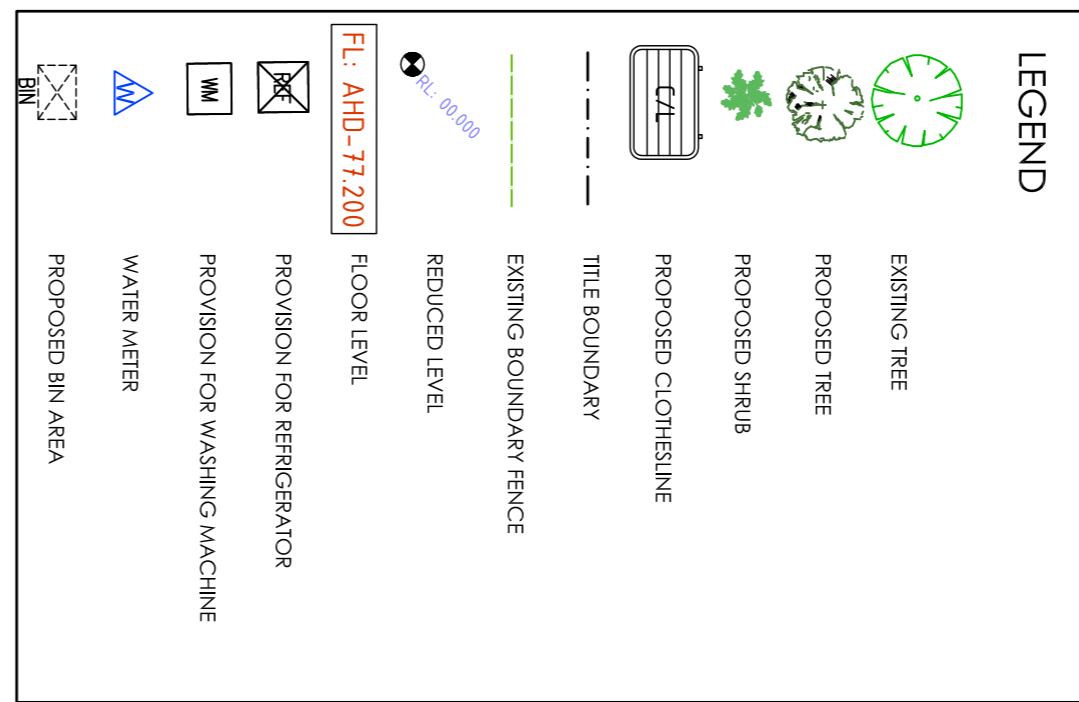

**TYPE OF SHED (TYPICAL) - OR SIMILAR SPANBLIT - GARDEN REEFER SHED (1 X SINGLE B75 DOOR)**

**DIMENSIONS -**  
 COMPACT STD (W2440 X D1530 X H1710 / roof W2440 X D1610)  
 VOLUME: 9M<sup>3</sup> FINISH: ZINCALUME

ALL LEVELS TO AHD

**Town Planning General Notes:**  
 This drawing has been released for Town Planning purposes only. This drawing is not to be used for construction. Unless stamped by council this drawing is in preliminary format and isn't appropriate for building purposes. This drawing is to be read in conjunction with Clause 55 report and any other associated documents submitted for town planning approval. This drawing is not to be altered without written consent from our office.

Rev: Date: Issue:

--	--	--

PRELIMINARY TOWN PLANNING

**Drawing Title:** GROUND FLOOR PLAN  
**Date:** 17th MAR 2019  
**Scale:** 1:100 @ A1

**Project Address:** Glenroy 3046

**Project Address:** Glenroy 3046  
**Client:** Glenn Nielsen  
**Job No.:** 145  
**Drawing:** TP01

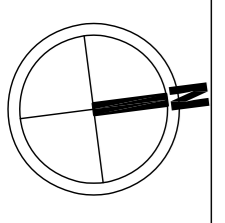

**metro building designers**  
 m: 0411 840 192  
 e: mtd@mtdod.com.au  
 w: www.metrobd.com.au